

LECOL DG100 series De-gassed unit

Feature

- ☆ **Multi-purpose** De-gassed cation conductivity design or re-boiling unit only.
- ☆ **Complete unit** Including all necessary components as a complete unit , just piping ,plug-in and ready to use.
- ☆ **Safety protection** Provide with necessary shell protection to prevent operators from hot injury.
- ☆ **Optional sample cooler** De-gassed by re-boiling only or cooling down by using optional sample cooler.

Application

LECOL DG100 series de-gassed unit is a complete design equipment to confirm the corrected conductivity value after re-boiling in cation conductivity measurement for boiler steam and water analysis application. Cation conductivity is a important parameter for boiler, most of the boiler manufacturers has specified the cation conductivity value should be below a certain conductivity limit (i.e. below 0.25 us/cm) to make sure no "leakage". Carbon dioxide or organics is the interference during the measurement, it can be heated up to "near to boiling" point and all the organics are volatized and removed which can reduce the interference and get the accurate reading.

Specifications

Power requirement : 110/220 VAC, 50/60 Hz

Flow range : 100 ~ 200 cc/min

Material : 316ss mounting plate, 316ss tubes and wetted parts in hot section

Sample inlet : 1/4" or 3/8" OD tube connection

Sample outlet : 1/2" NPT drain

Standard components : Flow meter, back pressure relief valve, heating column, temperature control panel, vent cylinder mounting plate.

Optional components : Cation resin columns, Conductivity analyzers, Free stand mounting rack/panel.



Ordering information

DG series de-gassed unit	DG100	X	X	X
De-gassed units 1 – Re-boiling unit 2 – Re-boiling unit plus de-gassed conductivity analyzer 3 – Re-boiling unit plus specific and de-gassed conductivity analyzers 4 – Re-boiling unit plus cation conductivity and de-gassed conductivity analyzers S – Others				
Resin columns 0 – None , for DG1001 only 1 – 1 resin column 2 – 2 resin columns in parallel (redundant usage) S – Others				
Mounting 0 – Mounting plate only 1 – Stainless steel construction free stand rack with painting 2 – Stainless steel construction free stand complete panel enclosure with painting 3 – Others				

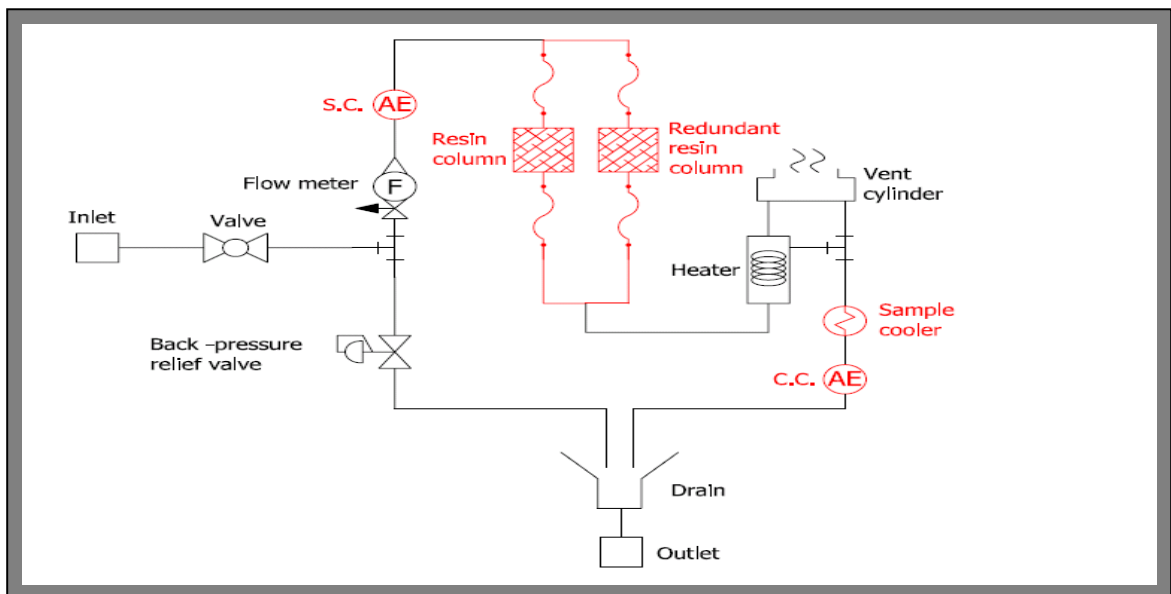

LECOL Luchan Enterprises Co., Ltd

No. 42, Mei Shan Road, Jen Mei Village, Kaohsiung Hsien, 83346 ; Taiwan
 TEL:+886-7-7336377 FAX:+886-7-7336353 E-mail:sales@luchan.com